

# APOLLO

Round LED Highbay



**Applications:** Retail, showrooms, commercial, convenience stores, supermarkets, shopping malls, warehouses, restaurants

## PERFORMANCE SUMMARY

Sunled's Apollo Series round LED High bay offers excellent ambient lighting with symmetrical lens options that deliver uniformity, glare control and visual comfort.

Its precision engineered modular heat sink design provides durability, optimal thermal control and longer system life; making the Apollo Series an attractive option for use in commercial, retail, and warehousing applications

## Construction

- Centralised flow-through convection system, pulls heat off both the optics and driving housing
- Compressed fin technology minimises heat resistance and improves dissipation effect for cool operation of vital electrical components
- Simple, uncluttered, elegant appearance

## Optics

- Injection moulded polycarbonate lens offers smooth illumination and versatility for use in retail and commercial applications
- Nichia LED COB
- Symmetrical distribution provides uniform light both to vertical or horizontal surfaces
- 100,000hrs long LED life span

## Electrical

- Meanwell driver features over-voltage and over-current control with short circuit protection and auto recovery
- DLC Premium 5.1 qualified product for maximum rebates
- 0-10v dimmable

## Specification

Volts: AC100-277V  
 Rated Life: L90/70,000hrs at 104°F  
 Environment Location: Wet Area  
 Impact Rating: IK08  
 Operating Temp: -22°F to 113°F  
 THD: <18% PF: >0.9  
 CRI: >RA73

## PRODUCT CODE

Example Apollo cat. 10045AL90HDIM



## PHOTOMETRICS

### 90° Acrylic

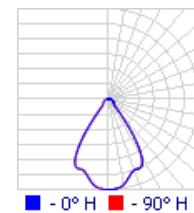
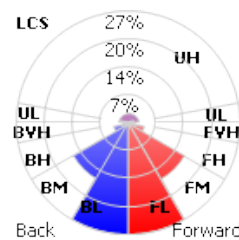

### 120° Aluminium

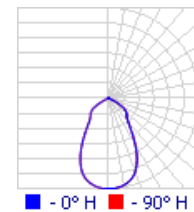
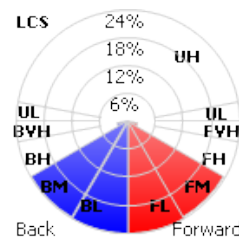

## REFLECTOR OPTIONS



**AC**  
Acrylic  
Reflector



**AL**  
Aluminium  
Reflector

Model No	Wattage (W)	CCT (°K)	Reflector	Distribution	Mounting	Control
Apollo	100 - 100W/11,000lms	4 - 4000	AC - Acrylic	90 - 90°	H - Hook	DIM - 0-10v Dimmable EM - Emergency Backup 0 - None
	150 - 150W/16,500lms	45 - 4500	AL - Aluminium	120 - 120°		
	200 - 200W/22,000lms	50 - 5000	0 - None			



# APOLLO

Round LED Highbay

## DIMENSIONS

### 200W

Weight: (May vary with accessories)  
14.4lbs (6.5kg)

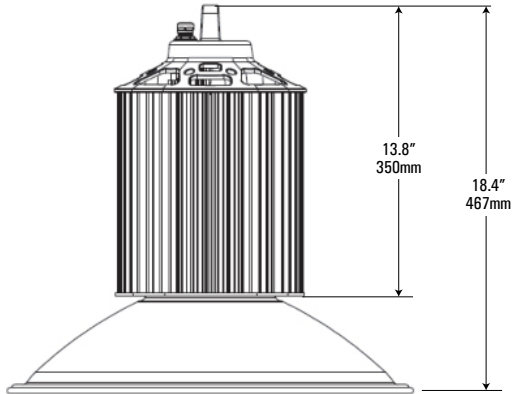

### 150W

Weight: 12.2lbs (5.5kg)

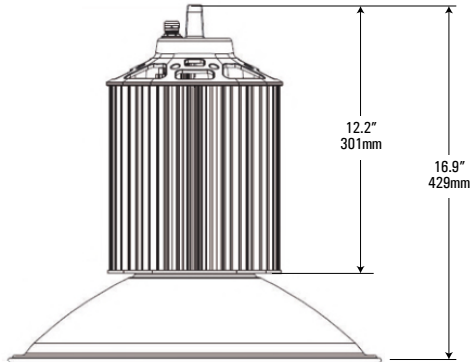

### 100W

Weight: 10.6lbs (4.8kg)

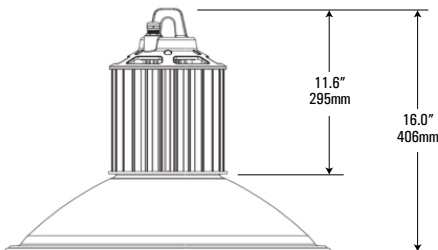

## REFLECTOR

### Acrylic (AC)

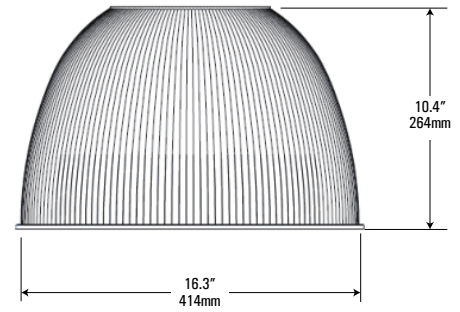

### Aluminium (AL)

