

CHALLENGER CLS

Vapor Tight LED Batten



Applications: Parking garages, industrial facilities, retail stores, garden centers, food services, airports

PERFORMANCE SUMMARY

The Challenger CLS vapor tight series from Sunled Industries is cost-efficient, wet-location listed and designed specifically for demanding environments.

It's multitude of sizes from 2 to 8ft and emergency options establish the CLS LED vapor tight fixture as an inexpensive solution for outdoor venues, canopies, locker rooms, passageways and under eave applications

Features

- Injection moulded UV stabilised vandal cover with high mechanical stress rating for challenging applications
- IP66 wet location listed withstanding dust and dirt environment
- Easy to install tool less access to lens and driver compartment
- 40°F suitable for installation in cold storage areas
- Factory fitted emergency battery backup available
- Premium operating efficiency of 130Lm/w
- DLC Premium qualified product
- Everyday illumination at the lowest possible price
- Easy to install tool less access to lens and driver compartment
- Quickfit bracket or optional suspension kit for simple installation

Specification

Volts: AC100-277V
 Average Rated Life: L80/50,000hrs
 CRI: RA80
 Beam Angle: 120°
 Environment Location: IP66
 Impact Rating: IK08
 Ambient Temp: -40°F to 122°F
 Emergency: 8W/90min

PRODUCT CODE

Example Challenger CLS cat. 2.24.3.PC.SS.0

Model No	Length	Wattage (W)	CCT (°K)	Accessories	Mounting	Control
Challenger CLS	2 - 2ft	24 - 24W/3,120lm	3 - 3000	PC - Polycarbonate Clips	S - Surface	MS - Internal Motion Sensor
	4 - 4ft	30 - 30W/3,900lm	4 - 4000	ST - Stainless Steel Clips	SS - Suspended	EM1 - 8W Emergency Backup
		40 - 40W/5,200lm	5 - 5000			EM2 - 25W Emergency Backup
	5 - 5ft	60 - 60W/7,800lm	6 - 6000			0 - None
	6 - 6ft	60 - 60W/7,800lm	60 - 60W/7,800lm			
80 - 80W/10,400lm						
100 - 100W/13,000lm						



PHOTOMETRICS

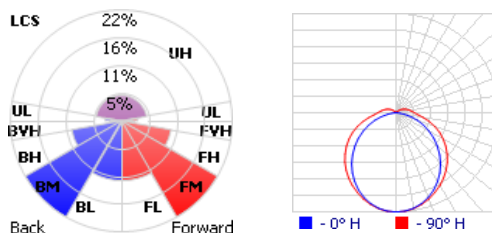

OPTIONS



PC
Polycarbonate Clips



SS
Stainless Steel



MS
Internal Motion Sensor



CHALLENGER CLS

Vapor Tight LED Batten

DIMENSIONS

2' Bar

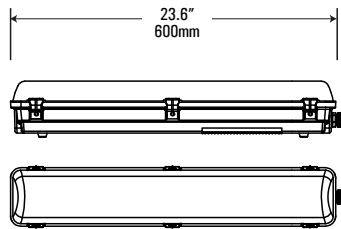

4' Bar

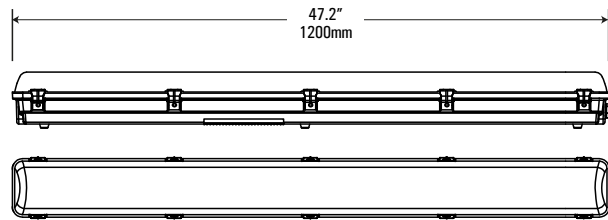

5' Bar

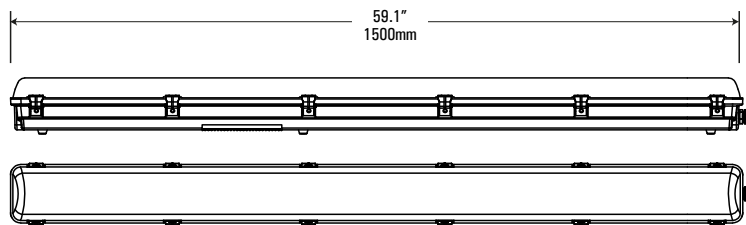

6' Bar

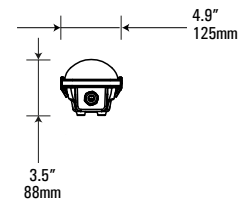
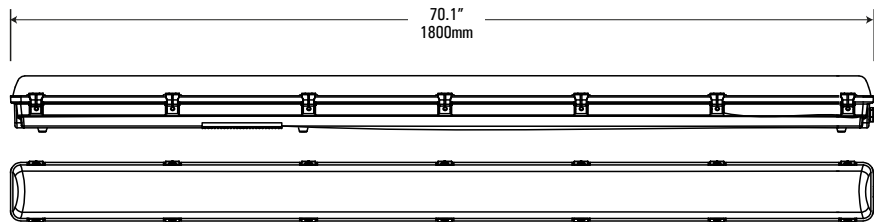

8' Bar

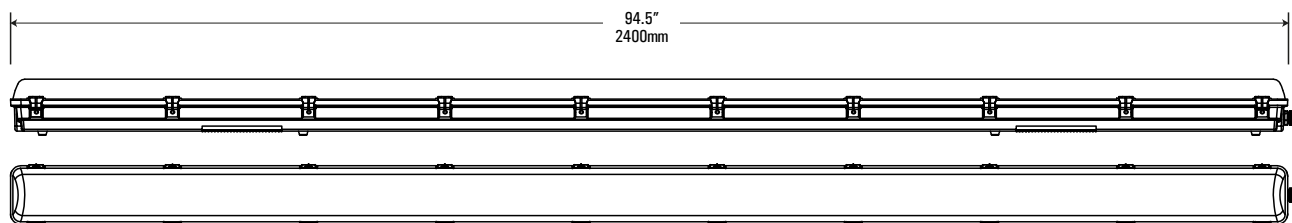

CHALLENGER CLS

Vapor Tight LED Batten

INSTALLATION

A

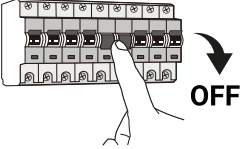

B

- 1 Drill $\Phi 6\text{mm}$ holes as shown on the drawing
- 2 Insert $\Phi 6\text{mm}$ expansion pipe in the wall, fix the mounting bracket by M4 screw

Length	Power	Fixing Center
2ft	24W	380mm
4ft	30-40W	730mm
6ft	60W	980mm
8ft	60-100W	1530mm

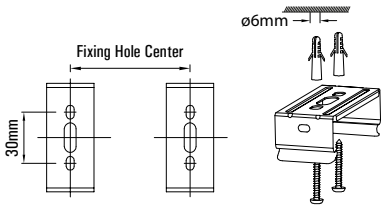

Safety Notice

- 1 Electrical installation should be done by a qualified electrician only
- 2 Disconnect the luminaire from and supply and wait until the luminaire cools down before replacing the driver
- 3 Never touch the lamp while luminaire is switched on
- 4 In any case of malfunction disconnect luminaire from supply immediately, and call a qualified electrician

C

- A Open the clips
- B Remove the diffuser
- C Hold the stainless fixator, remove the gear tray

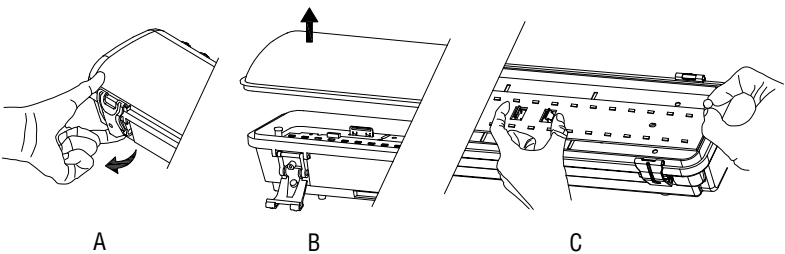

D

- 1 Loosen cable gland tightening nut, insert the cable through the gland

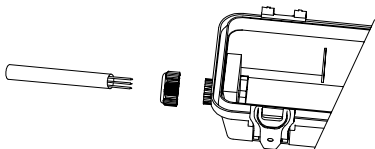

- 2 Connect the cable on the terminal block as below and tighten the cable gland

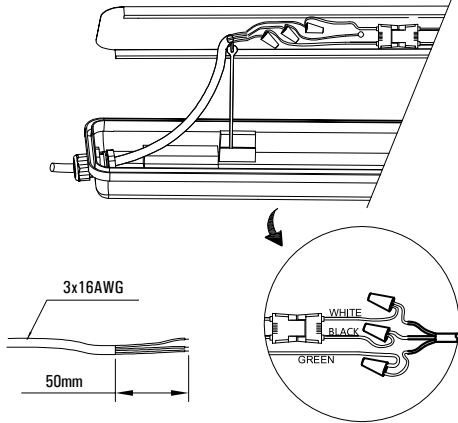

3x16AWG
50mm

E

- 1 Fix light to the ceiling

