

# EAGLE EYE

Parking and Area Luminaire



**Applications:** Parking lots, general area lighting, sporting facilities, roadway, car dealerships

## PERFORMANCE SUMMARY

The modern styling of the Eagle Series is striking yet unobtrusive — making a bold and contemporary statement even as it blends elegantly with its environment. The Eagle Series instills the benefits of the latest in LED technology into a high performance, high efficacy, long-life luminaire.

The outstanding photometric performance available in 4 IES distributions, results in sites with excellent uniformity, greater pole spacing and lower power density for a wide range of applications

## Construction

- Aesthetically refined housing suitable for retail and commercial settings
- Weathertight IP65 sealed lens and PC diffuser
- Heavy duty die cast aluminium alloy construction
- Direct, yoke or slipfitter adjustable mount attachments, adaptable to a wide range of project applications
- DLC Premium 5.1 qualified product

## Optics

- Adjustable lens can be rotated left or right 90 and 180°
- Available in 4 professional distributions T2/T3/T4/T5
- Exceptional operating efficiency of 145lm/W

## Electrical

- High efficiency LED Driver, with wide range input voltage AC100-277V (1-10VDC Dimmable)
- Optional twistlock photocell and microwave sensor control
- 10kV built in surge protection

## Specification

Volts: AC100-277V  
 Average Rated Life: L70 at 50,000hrs  
 CRI: >RA70  
 Impact Rating: IK08  
 Environment Location: IP65  
 Surge: 6kV line-line, 10kV line earth  
 Ambient Temp: -22°F to 113°F  
 PF: >0.9

## PRODUCT CODE

Example Eagle Eye cat. 100T2345GGSLRC

Model No	Wattage (W)	Distribution	CCT (°K)	Finish	Bracket	Control
Eagle Eye	80 - 80W/11,600 lms	T2 - Type 2	345 - CCT Tunable	BR - Bronze	SL - Slipfitter	PE - Photocell
	100 - 100W/14,500 lms	T3 - Type 3	3000/4000/5000	BK - Black	DM - Direct Mount	MS - Motion Sensor
	150 - 150W/21,000 lms	T4 - Type 4	3 - 3000	GG - Gray	YM - Yoke	RC - Remote Control
	200 - 200W/29,000 lms	T5 - Type 5	4 - 4000		DA - Direct Mount Adjustable	O - None
	240 - 240W/34,800 lms	+ES - External Glare Shield	5 - 5000			
	300 - 300W/42,000 lms	+EV - External 360° Full Visor				



## DIMENSIONS

### 200/240/300W

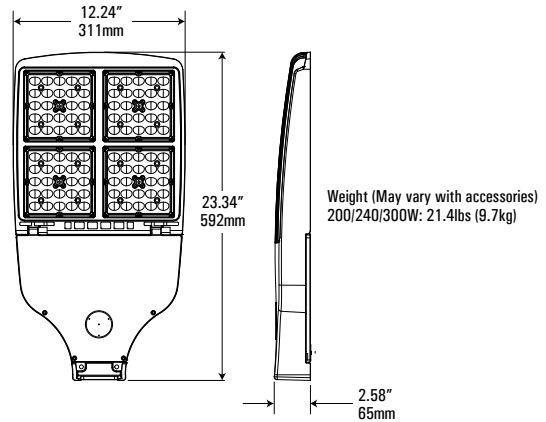

### 80/100/150W

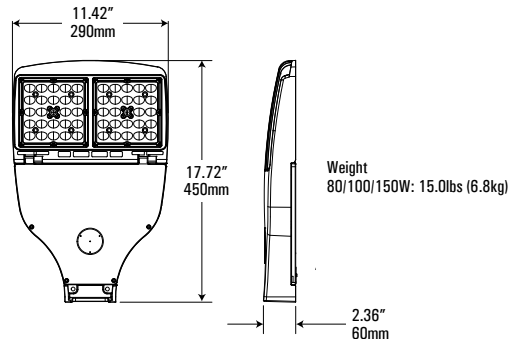

# EAGLE EYE

Parking and Area Luminaire

## EPA SQ.FT

Configuration	80/100/150W	200/240/300W
1	0.5	0.63
2x180°	1.0	1.26
2x90°	0.77	0.82
3x90°	1.27	1.44
3x120°	0.93	1.26
4x90°	1.27	1.44

## MOUNTING OPTIONS



**SL**  
Slipfitter



**DM**  
Direct Mount



**YM**  
Yoke Mount



**DA**  
Direct Mount  
Adjustable

## CONTROL



**PE**  
Photocell



**MS**  
Motion Sensor



**345**  
Tunable CCT



**RC**  
Remote  
Control

## EXTERNAL SHIELDS

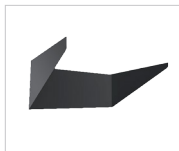

**ES**  
External Glare  
Shield



**EV**  
360° Full  
Visor

## PHOTOMETRICS

### Type 2 (T2)

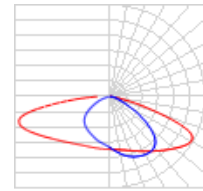
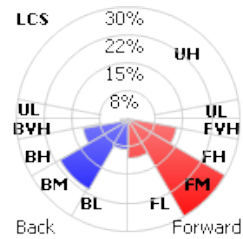

### Type 3 (T3)

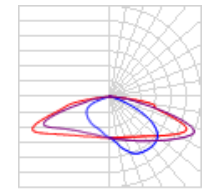
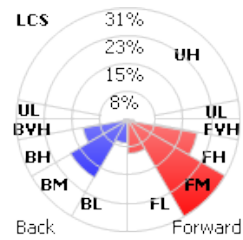

### Type 4 (T4)

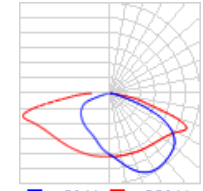
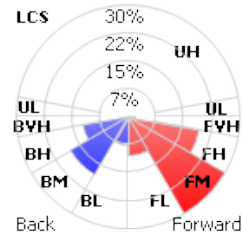

### Type 5 (T5)

